

4

3

2

1

D

D

C

C

B

B

A

A

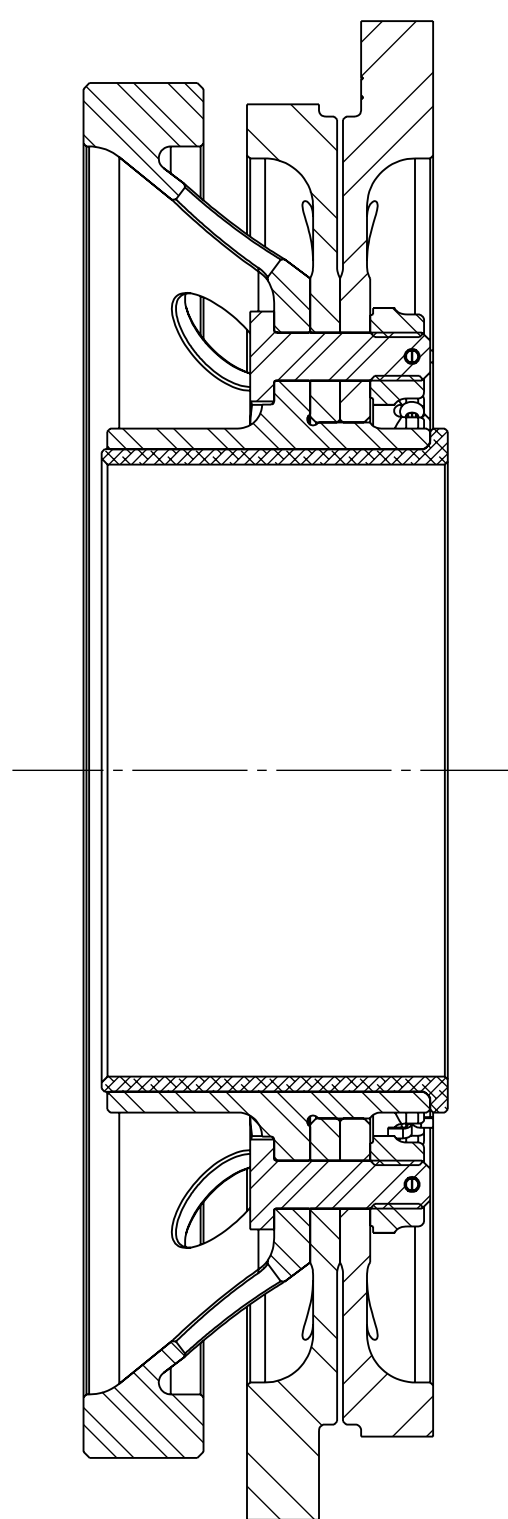
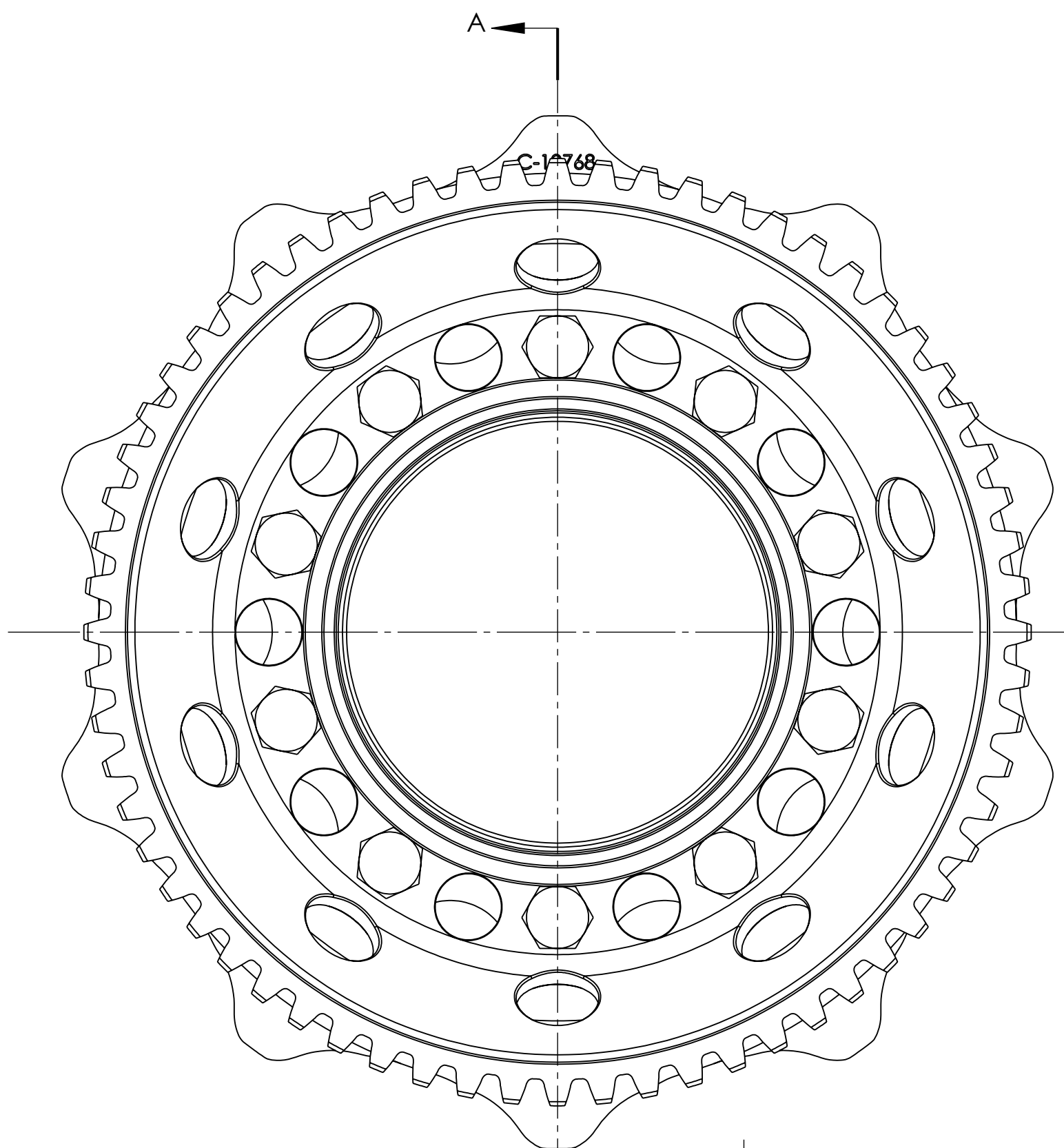

SECTION A-A

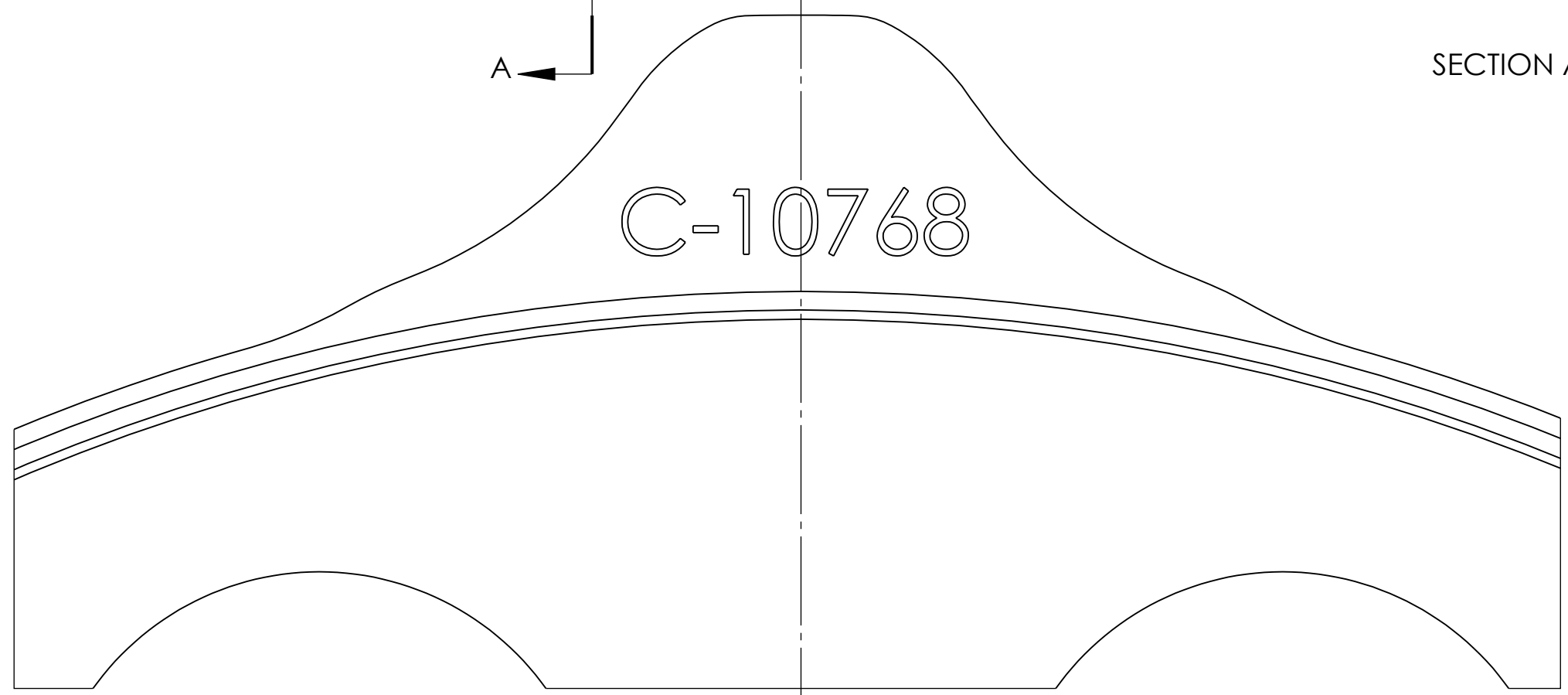
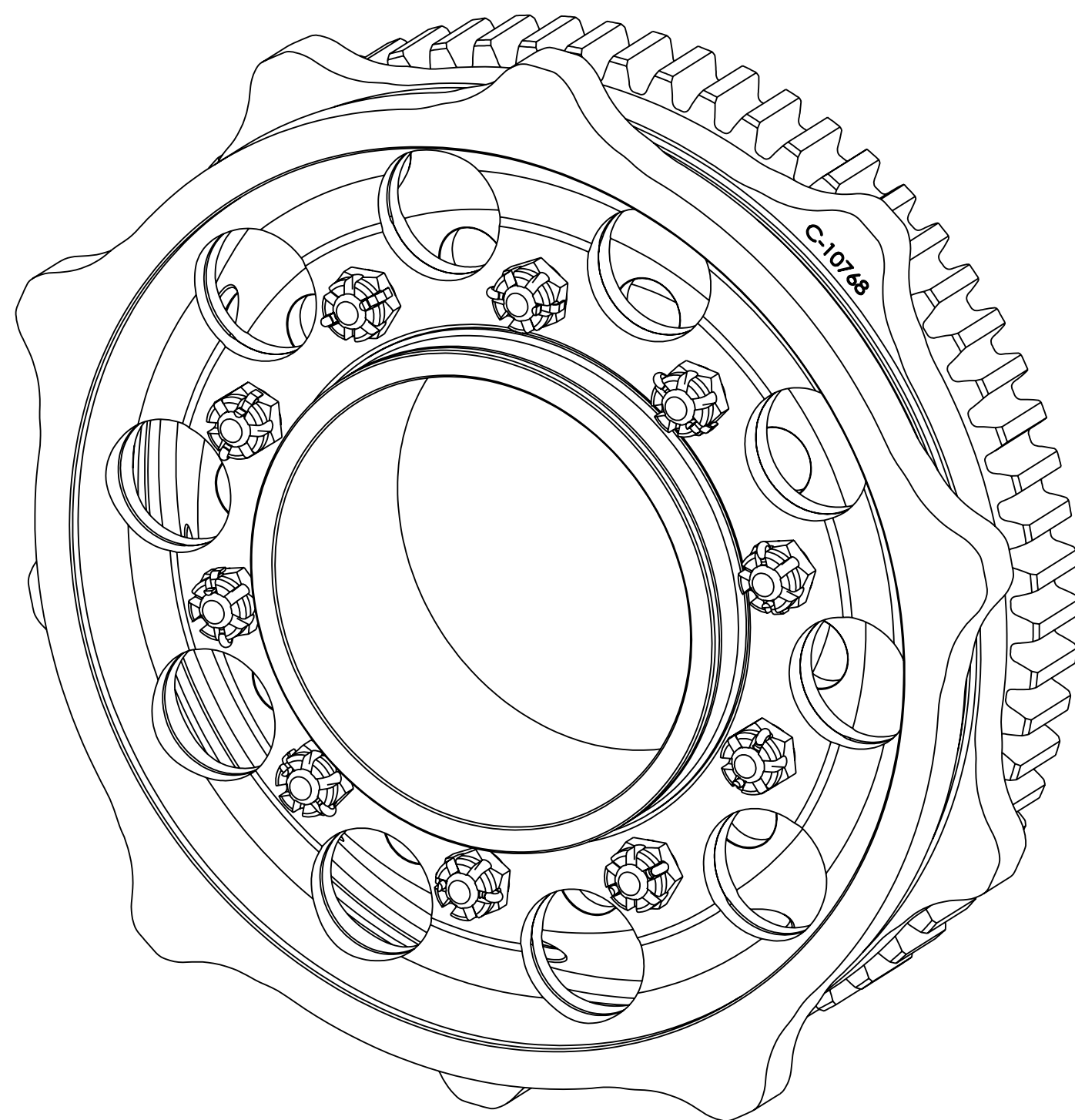

DETAIL B
SCALE 4 : 1

C-10225B Cam Gear Assy Complete (Intermediate).

Intermediate and Late production Challenger Engines were equipped with eccentric valve tappet guides for the No's. 2, 3, 5 and 6 cylinders.

This Cam Assy. was originally factory installed on the following engines:
Serial numbers available by request , contact via AEHS Bulletin Board.

A complete Cam and eccentric Valve Tappet Guide kit was available for field installation.

J Riend 26nov22

NOTE:
These drawings may be used solely for non-commercial use such as historical research, exhibition, model-making, or for non-profit restoration purposes. Models or restored aircraft must remain inoperable and incapable of flight. Drawings may not be used to restore operable aircraft, or engines, to an airworthy status or building flyable or operable reproductions or restorations.

4

3

2

1